

R586R



Energy
Management

Distribution and control units

Datasheet
0861EN 01/2024

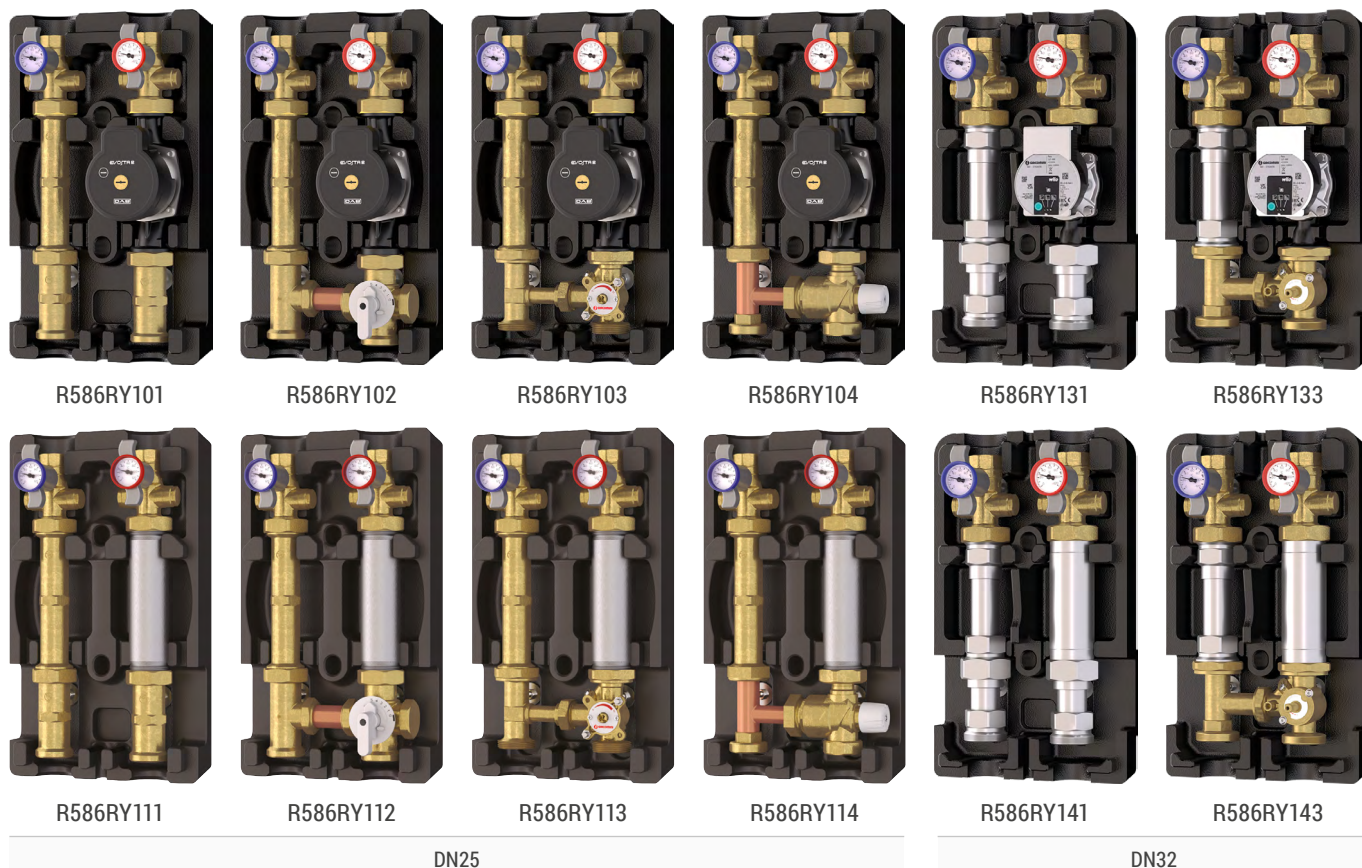

R586R distribution units control heating or cooling for one zone of the system. The units are equipped with shut-off ball valves with integrated thermometer, check valve integrated in the return circuit and polypropylene foam rigid insulation (EPP). They are available with a low-energy consumption pump complying with directive ErP 2009/125/CE or with a steel spacer for pump installation. Some versions also feature a mixing valve; the actuator to control the mixing valve (when included) is sold separately. The mixing valve actuators and the supply temperature can be controlled with KLIMAbus thermoregulation products.



Unit with insulation and
actuator (optional)



© VIDEO
Frame the QR code with your smartphone or tablet
to view the video tutorial.

➤ Versions and product codes

Versions with pump included

PRODUCT CODE	CONNECTIONS			APPLICATION	PUMP	MIXING	
	DN	BOILER ROOM SIDE	SYSTEM SIDE			MIXING VALVE	ACTUATOR (OPTIONAL)
R586RY101				Heating/Cooling	DAB EVOSTA2 70/180	-	-
R586RY102	25	G 1-1/2"M	G 1"F	Heating/Cooling	DAB EVOSTA2 70/180	Ball mixing valve Kv 18,9 (R296)	K275Y002/011/013
R586RY103				Heating/Cooling	DAB EVOSTA2 70/180	Sector mixing valve Kv 10 (R297)	K275Y002/011/013
R586RY104				Heating only	DAB EVOSTA2 70/180	Thermostatic mixing valve Kv 3,6	-
R586RY131	32	G 2"M	G 1-1/4"F	Heating/Cooling	Wilo Para 30/7	-	-
R586RY133				Heating/Cooling	Wilo Para 30/7	Sector mixing valve Kv 18	K275Y002/011/013

Versions without pump

PRODUCT CODE	CONNECTIONS			APPLICATION	PUMP	MIXING	
	DN	BOILER ROOM SIDE	SYSTEM SIDE			MIXING VALVE	ACTUATOR (OPTIONAL)
R586RY111				Heating/Cooling	Not included	Ball mixing valve Kv 18,9 (R296)	-
R586RY112	25	G 1-1/2"M	G 1"F	Heating/Cooling	Not included	Sector mixing valve Kv 10 (R297)	K275Y002/011/013
R586RY113				Heating/Cooling	Not included	Thermostatic mixing valve Kv 3,6	K275Y002/011/013
R586RY114				Heating only	Not included	-	-
R586RY141	32	G 2"M	G 1-1/4"F	Heating/Cooling	Not included	Sector mixing valve Kv 18	-
R586RY143				Heating/Cooling	Not included	Sector mixing valve	K275Y002/011/013

Optional components

- **K275Y002:** actuator with integrated constant temperature regulator
- **K275Y011:** 3-point floating actuator controllable with KLIMAbus thermoregulation
- **K275Y013:** actuator 0÷10 V controllable with KLIMAbus thermoregulation
- **R284Y021:** differential by-pass kit
- **R252Y001:** shut-off ball valve G 1"F x nut G 1-1/2"F, for installation upstream the distribution unit
- **R252Y002:** shut-off ball valve G 1-1/4"F x nut G 2"F, for installation upstream the distribution unit
- **KLIMAbus thermoregulation:** thermoregulation components (electronic controller, thermostats, ambient probes, etc...)

Compatible pumps with DN25 units

- **P76DAY001:** DABEVOSTA270/180-180mm center distance, G 1-1/2"M connect.; 230 V; 50 Hz; 45 W; ErP 2009/125/CE compliant (spare part for units equipped with pump)
- **P76WIY019:** Wilo Para 25/9 (high flow rate) - 180 mm center distance, G 1-1/2"M connections; 230 V; 50 Hz; 87 W; ErP 2009/125/CE compliant (to be ordered separately for groups without pump)

Compatible pumps with DN32 units

- **P76WIY020:** Wilo Para 30/7 - 180 mm center distance, G 2"M connections; 230 V; 50 Hz; 50 W; ErP 2009/125/CE compliant (spare part for units equipped with pump)
- **P76WIY021:** Wilo Maxo 30/10 (high flow rate) - 180 mm center distance, G 2"M connections; 230 V; 50 Hz; 190 W; ErP 2009/125/CE compliant (to be ordered separately for units without pump)

Other compatible pumps

- Grundfos Alpha series - 180 mm center distance, G 1-1/2"M connections

➤ General technical data

- Fluids: water, glycol-based solutions (max. 50 %)
- Temperature range: 5÷100 °C (5÷95 °C for R586RY104/114)
- Max. working pressure: 10 bar (5÷95 °C for R586RY104/114)
- Connections: boiler room side: G 1-1/2" M or G 2" M
system side: G 1" F or G 1-1/4" F
outputs center distance: 125 mm
- Galvanized steel spacer, 180 mm center distance (for pump-free versions)
- Shut-off ball valves with thermometers (scale 0÷120 °C) and connections for by-pass kit
- Check valve integrated on return circuit
- EPP insulation, density 35 kg/m³
- Wall-mount plate (screw anchors not included)

🔗 **NOTE.** Specific data referring to single R586R units are given in the following corresponding paragraph.

Materials

- Shut-off ball valves: CW617N brass body, PTFE sealings, plastic handle
- Spacer with check valve: galvanized steel body, POM check valve
- Polypropylene foam insulation (EPP)
- Gaskets: EPDM

➤ Installation positions

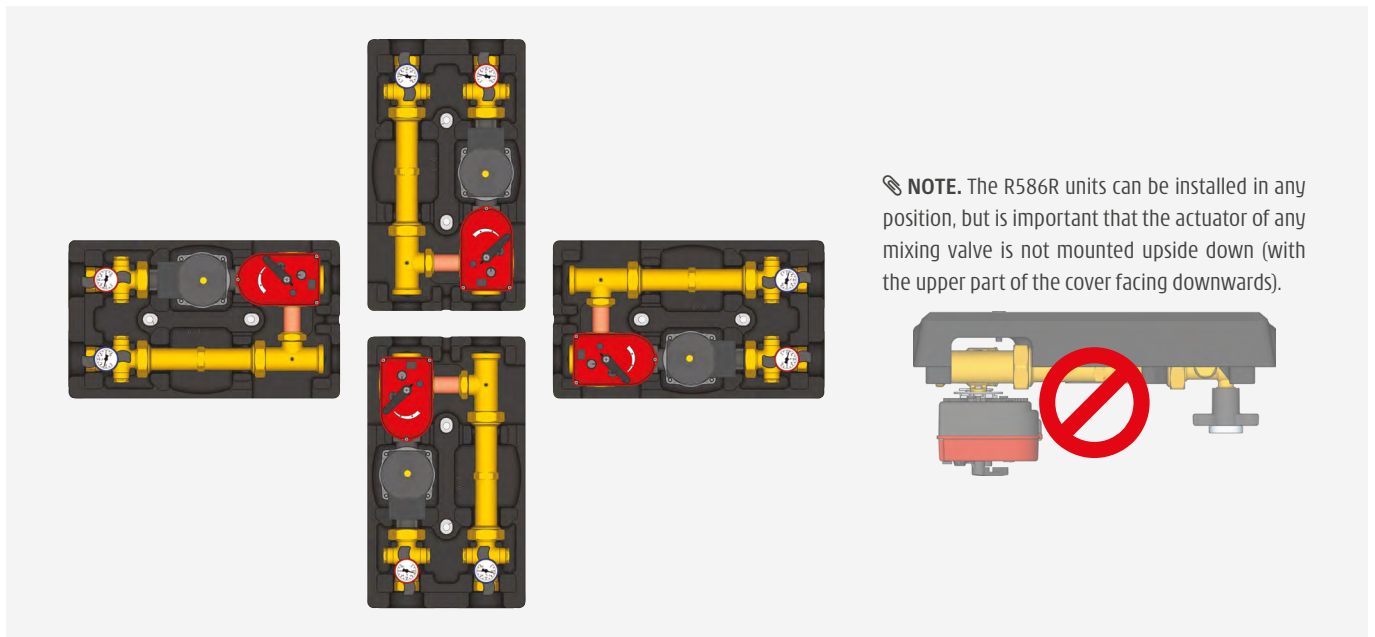

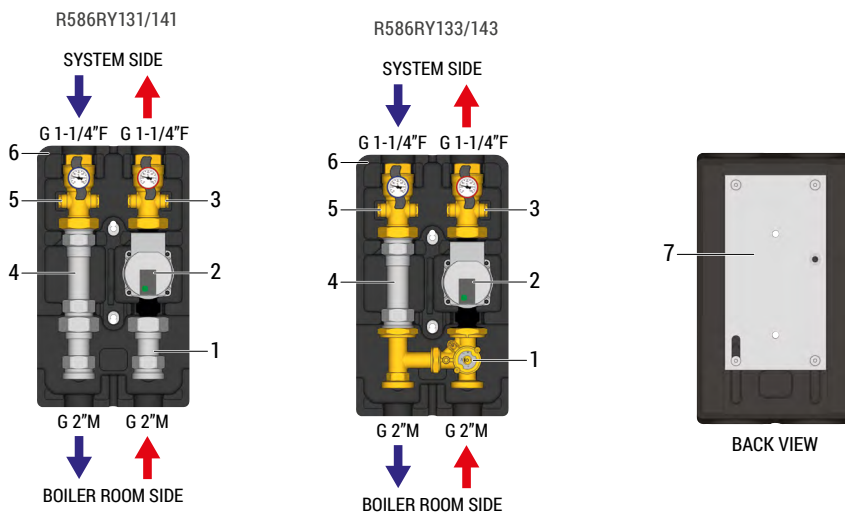
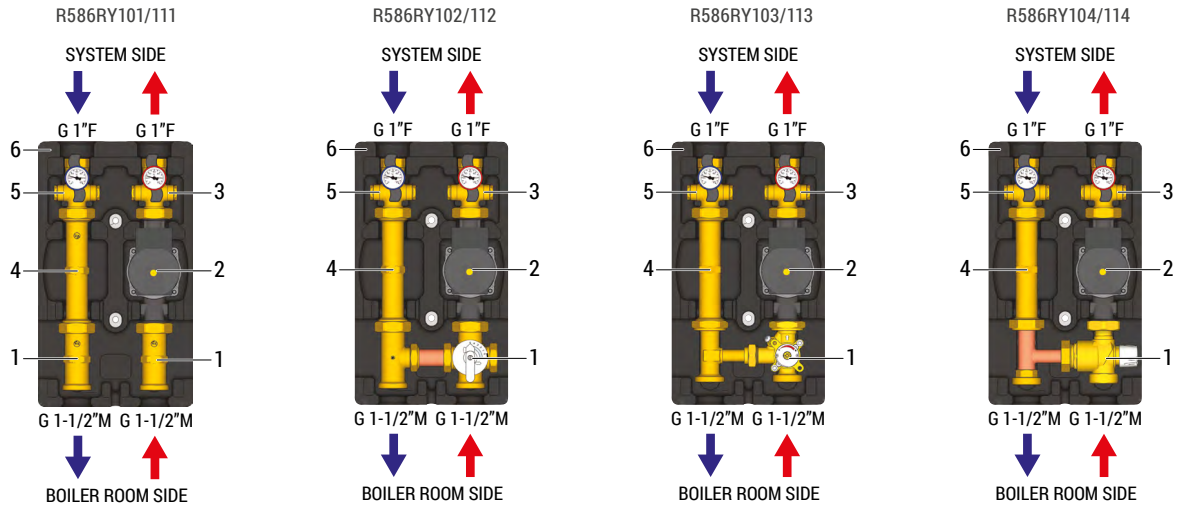

REF.	R586RY101/111	R586RY102/112	R586RY103/113	R586RY104/114	R586RY131/141	R586RY133/143
1	Brass fitting	Mixing ball valve (R296)	Mixing sector valve (R297)	Mixing thermostatic valve	Galvanized steel spacer	Mixing sector valve
2	Pump or galvanized steel spacer	Pump or galvanized steel spacer	Pump or galvanized steel spacer	Pump or galvanized steel spacer	Pump or galvanized steel spacer	Pump or galvanized steel spacer
3	Supply ball valve, with thermometer and connections for by-pass kit	Supply ball valve, with thermometer and connections for by-pass kit	Supply ball valve, with thermometer and connections for by-pass kit	Supply ball valve, with thermometer and connections for by-pass kit	Supply ball valve, with thermometer and connections for by-pass kit	Supply ball valve, with thermometer and connections for by-pass kit
4	Brass spacer with integrated check valve	Brass spacer with integrated check valve	Brass spacer with integrated check valve	Brass spacer with integrated check valve	Steel spacer with integrated check valve	Steel spacer with integrated check valve
5	Return ball valve, with thermometer and connections for by-pass kit	Return ball valve, with thermometer and connections for by-pass kit	Return ball valve, with thermometer and connections for by-pass kit	Return ball valve, with thermometer and connections for by-pass kit	Return ball valve, with thermometer and connections for by-pass kit	Return ball valve, with thermometer and connections for by-pass kit
6	Insulation shell	Insulation shell	Insulation shell	Insulation shell	Insulation shell	Insulation shell
7	Wall-mount plate	Wall-mount plate	Wall-mount plate	Wall-mount plate	Wall-mount plate	Wall-mount plate

➤ Main features

Supply/return outputs reversibility

All the units include reversible supply and return outputs.

R586RY101/111/131/141

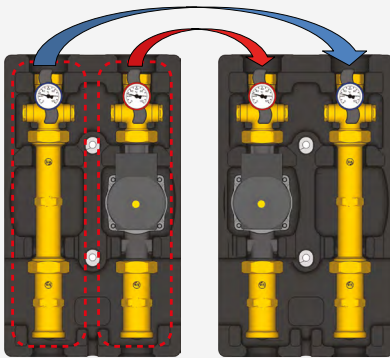

Invert supply and return by fitting the outputs in the insulation slots.

R586RY102/112

Option 1

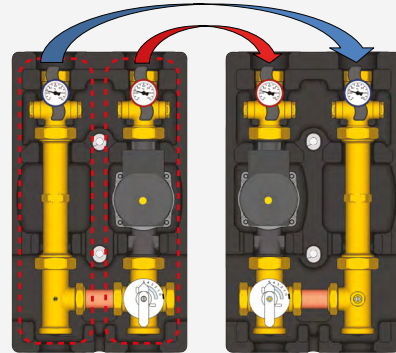

Invert supply and return by fitting the outputs in the insulation slots. Also invert the cap and the copper fitting of the mixing valve.

R586RY103/113/133/143

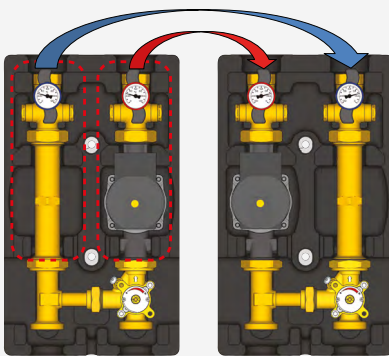

Leave the mixing valve in the default position, invert supply and return by fitting the outputs in the insulation slots. In this configuration the mixing valve works by mixing the water coming from the supply.

Option 2

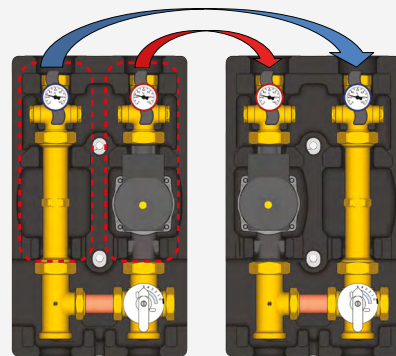

Leave the mixing valve in the default position, invert supply and return by fitting the outputs in the insulation slots. In this configuration the mixing valve works by mixing the water coming from the supply.

R586RY104/114

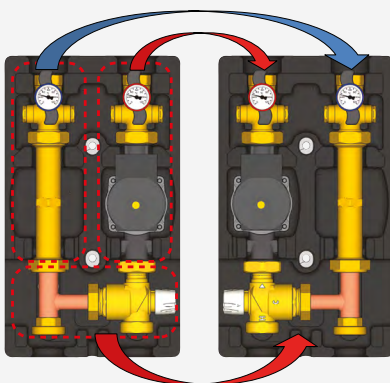

180°
Invert supply and return by fitting the outputs in the insulation slots and turn the mixing valve upside down.

Check valve integrated on return output

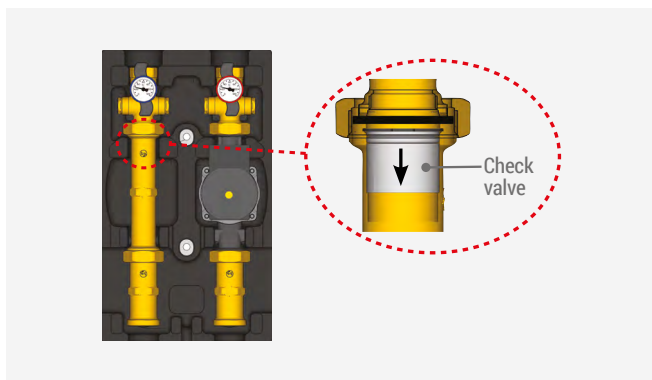

All R586R units include a check valve inside the brass spacer top, on the return output. The check valve can be disassembled by removing the Seeger ring used to fit it to the spacer.

Installation of R252 ball valves

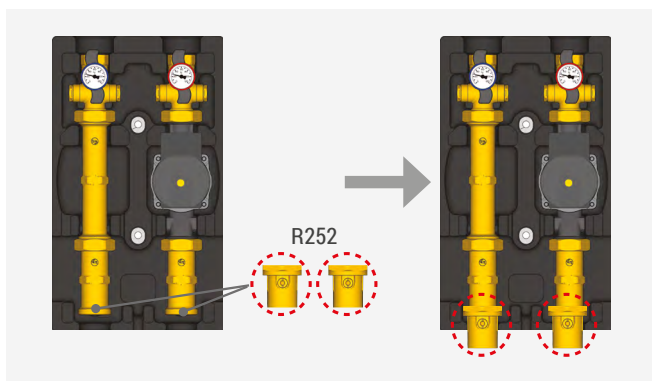

R586R units can be intercepted by installing the R252 ball valves upstream. The ball valves can be opened and closed using a 5 mm Allen key.

Installation of R284Y021 differential by-pass kit

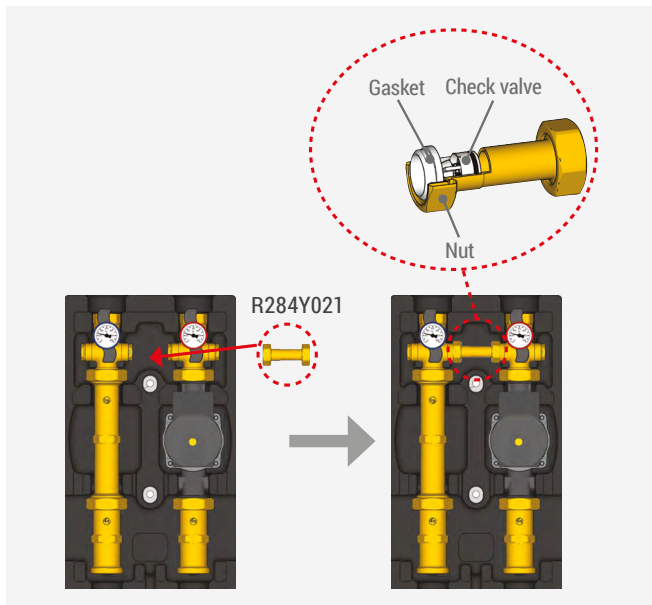

The differential by-pass kit protects the pump enabling water recirculation inside the R586R unit when the secondary system is off or completely closed. The kit includes a brass spacer with integrated check valve calibrated at a fix value of 5 m.w.c., two nuts to be screwed on the shut-off valves and two PTFE gaskets.



R586RY101 / R586RY111

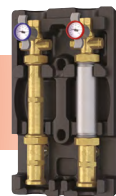

➤ Operation

R586RY101 and R586RY111 distribution units without mixing valve are used in heating and cooling systems such as relaunching units for direct outputs of high/low temperature combined systems.

The units include shut-off valves with thermometer both on the supply and return circuit and a check valve on the return spacer.

The two supply and return outputs are reversible and a R284Y021 differential by-pass kit can be installed in between (see paragraph "Main characteristics").

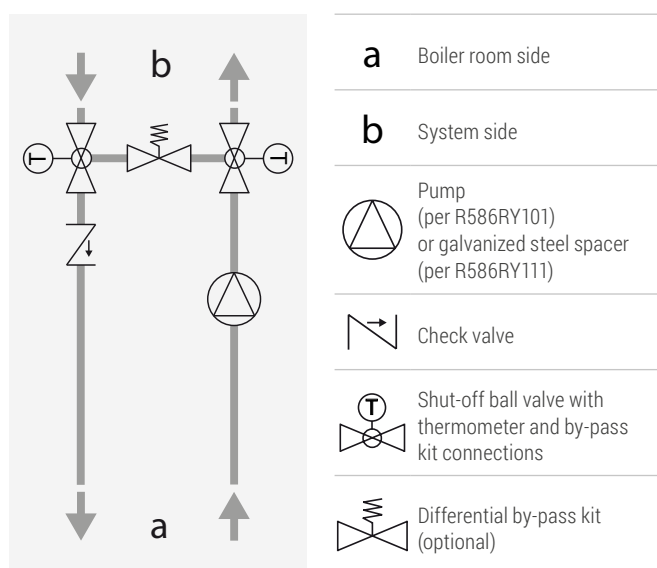

➤ Specific technical data

- Temperature range: 5÷100 °C
- Max. working pressure: 10 bar
- Connections: boiler room side: G 1-1/2" M
system side: G 1" F
outputs center distance: 125 mm
- Weight: 5,8 kg (with pump); 4,0 kg (without pump)

Materials

- Shut-off ball valves: CW617N brass body, PTFE sealings, plastic handle
- Spacer with check valve: galvanised steel body, POM check valve
- Polypropylene foam insulation (EPP)
- Gaskets: EPDM

Flow rate/power/hydraulic head diagram

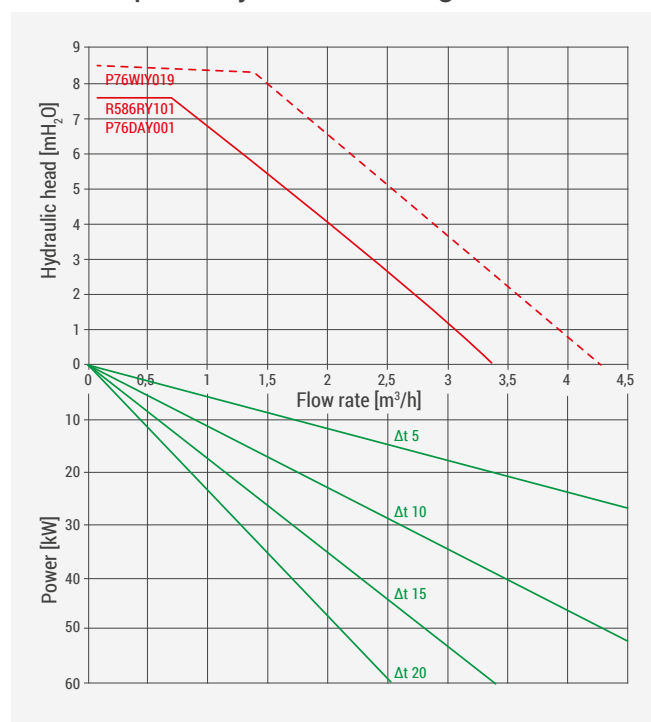

NOTE. For proper interpretation of the diagram, see example on page 17.

NOTE. Curves obtained with pump set to "constant speed, level III" mode.

NOTE. Diagram referring to the useful hydraulic head at the unit connections.



R586RY102 / R586RY112



Operation

R586RY102 and R586RY112 distribution units with mixing ball valve (R296) can be used in heating and cooling systems to control the system supply temperature.

Operation is possible only when combined to an actuator and possibly a KLIMAbus thermoregulation system.

The units include an shut-off valve with thermometer on both supply and return circuits and a check valve on the return spacer.

The two supply and return outputs are reversible and a R284Y021 differential by-pass kit can be installed in between (see paragraph "Main characteristics").

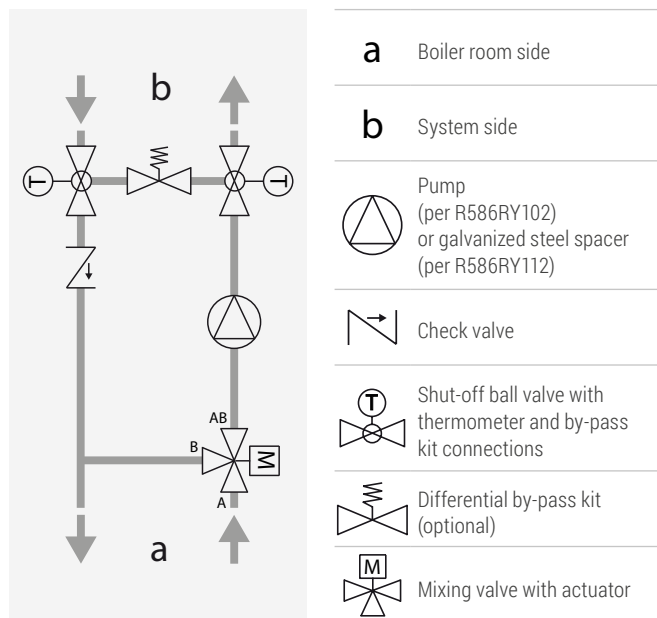

Kv R296 mixing valve

• Kv: 18,9

Manual handle position	0 (B→AB)	1	2	3	4	5 (A→AB)
Kv (AB)	2,0	4,8	7,8	9,8	14,1	18,9

Specific technical data

- Temperature range: 5÷100 °C
- Max. working pressure: 10 bar
- Connections: boiler room side: G 1-1/2" M
system side: G 1" F
outputs center distance: 125 mm
- Weight: 6,8 kg (with pump); 5,0 kg (without pump)

Materials

- Shut-off ball valves: CW617N brass body, PTFE sealings, plastic handle
- Mixing valve: brass body, plastic handle, hard drawn copper pipe connecting supply and return circuits, EPDM gaskets
- Spacer with check valve: galvanized steel body, POM check valve
- Polypropylene foam insulation (EPP)
- Gaskets: EPDM

Flow rate/power/hydraulic head diagram

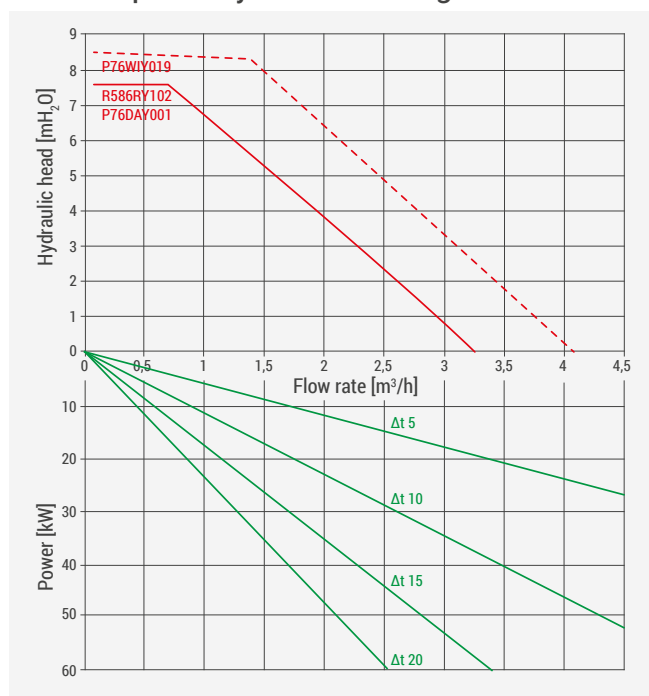

NOTE. For proper interpretation of the diagram, see example on page 17.

NOTE. Curves obtained with pump set to "constant speed, level III" mode.

NOTE. Diagram referring to the useful hydraulic head at the unit connections and mixing valve fully open.



R586RY103 / R586RY113



➤ Operation

R586RY103 and R586RY113 distribution units with R297 mixing sector valve can be used in heating and cooling systems to control the system supply temperature.

Operation is possible only when combined to an actuator and possibly a KLIMAbus thermoregulation system.

The units include an shut-off valve with thermometer on both supply and return circuits and a check valve on the return spacer.

The mixing valve is also equipped with a manually adjustable by-pass to insert the function of fixed recirculation of the system.

The two supply and return outputs are NOT reversible (see "Main Characteristics" paragraph) and a R284Y021 differential by-pass kit can be installed in between (see paragraph "Main characteristics").

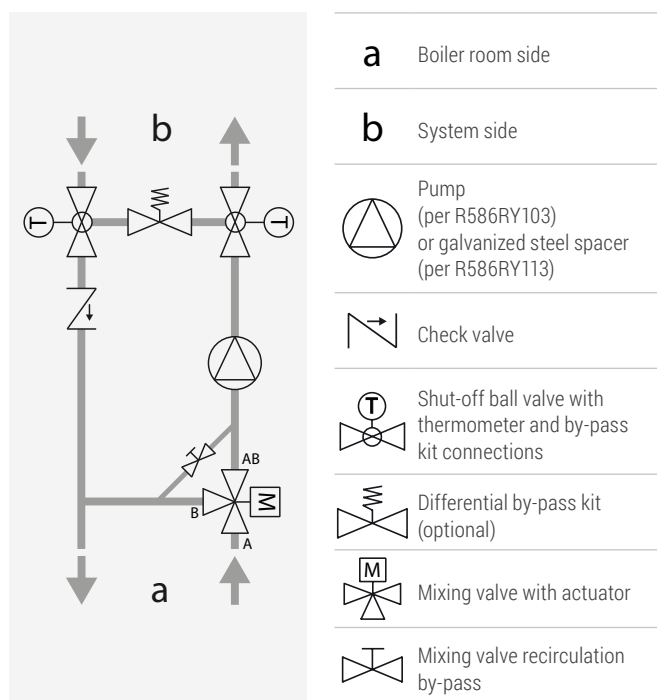

➤ Specific technical data

- Temperature range: 5÷100 °C
- Max. working pressure: 10 bar
- Connections: boiler room side: G 1-1/2" M
system side: G 1" F
outputs center distance: 125 mm
- Weight: 6,7 kg (with pump); 4,9 kg (without pump)

Materials

- Shut-off ball valves: CW617N brass body, PTFE sealings, plastic handle
- Valvola miscelatrice: corpo in ottone, tubo di raccordo in ottone, Gaskets in EPDM, FPM e PTFE.
- Spacer with check valve: galvanneated steel body, POM check valve
- Polypropylene foam insulation (EPP)
- Gaskets: EPDM

Flow rate/power/hydraulic head diagram

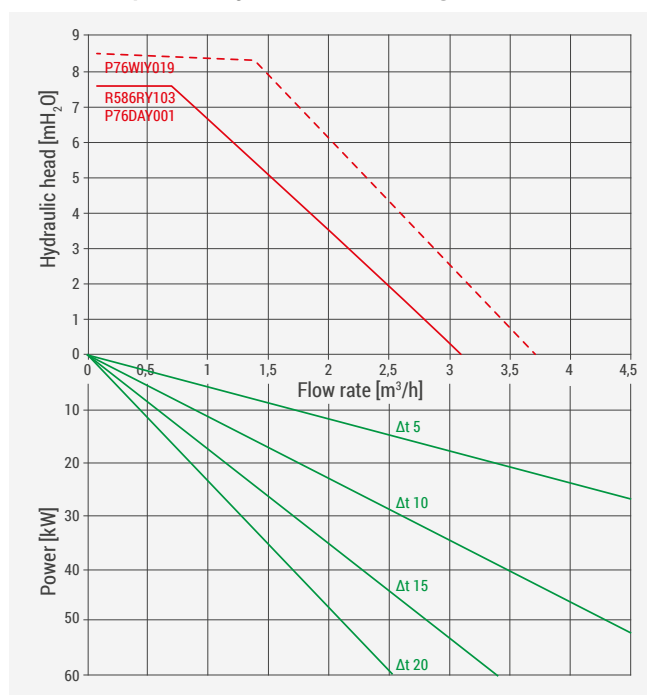

NOTE. For proper interpretation of the diagram, see example on page 17.

NOTE. Curves obtained with pump set to "constant speed, level III" mode.

NOTE. Diagram referring to the useful hydraulic head at the unit connections and mixing valve fully open.

R297 mixing valve Kv

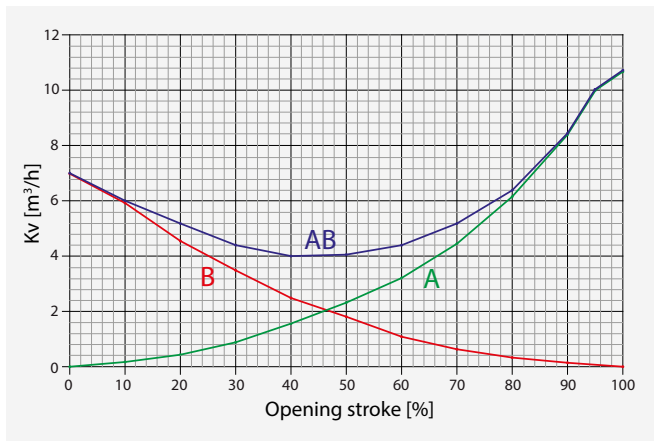

Equal percentage valve: to absolute value variations of the stroke always corresponds the same % variation of the outflow coefficient (example: if the valve opens by 10 %, the Kv will vary by 10 %), notwithstanding the position of the recirculation by-pass.

- Kv: 10

Operation of mixing valve recirculation by-pass

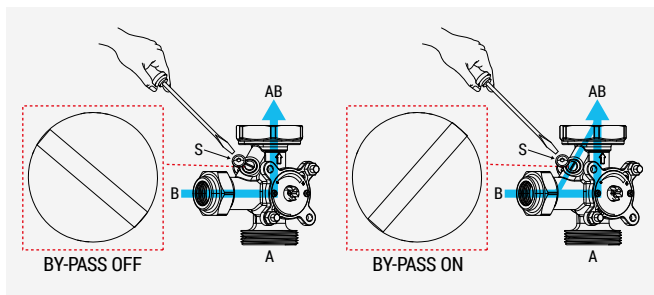

R297 mixing valves include a by-pass which activates a fix recirculation on the mixing valve (B→AB).

⚠ WARNING. Do not loosen the safety device (S) next to the by-pass adjustment screw. High pressures may violently eject it from its seat.



R586RY104 / R586RY114

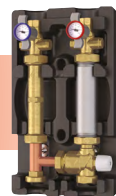

Operation

R586RY104 and R586RY114 distribution units with mixing thermostatic valve can be used in heating-only systems to control the system supply temperature and maintain it at the desired constant temperature.

The setting range of the mixing thermostatic valve allows for applications on low-temperature radiant systems and/or fan-coil applications.

The units include shut-off valves with thermometer on both supply and return circuits and a check valve on the return spacer.

The two supply and return outputs are reversible and the R284Y021 differential by-pass kit can be installed in between (see paragraph "Main characteristics").

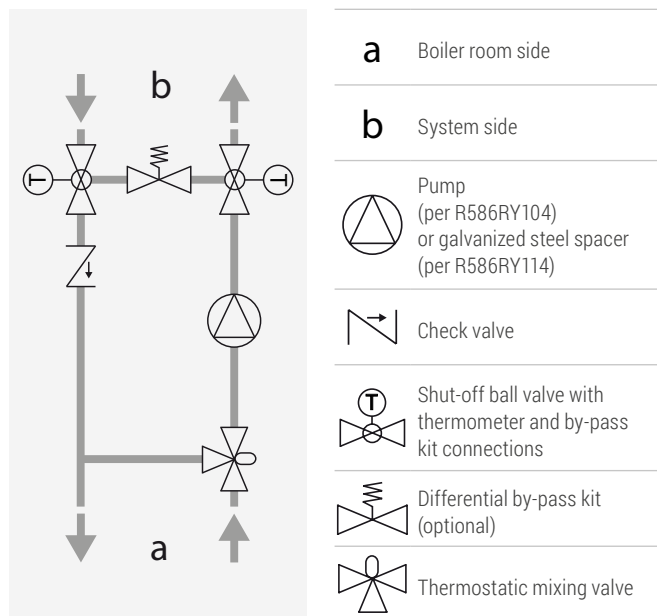

Thermostatic mixing valve

- Kv: 3,6
- Sensitivity: ± 2 °C

Handwheel position	Min.	1	2	3	4	5	Max.
Temperature [°C]	29	30	40	47	54	60	64

Specific technical data

- Temperature range: 5÷95 °C
- Max. working pressure: 5 bar
- Connections: boiler room side: G 1-1/2" M
system side: G 1" F
outputs center distance: 125 mm
- Weight: 7,0 kg (with pump); 5,2 kg (without pump)

Materials

- Shut-off ball valves: CW617N brass body, PTFE sealings, plastic handle
- Valvola miscelatrice: corpo in ottone, otturatore in PSU GF20, molla in acciaio inox, Gaskets in EPDM, sensore a cera.
- Spacer with check valve: galvannead steel body, POM check valve
- Polypropylene foam insulation (EPP)
- Gaskets: EPDM

Flow rate/power/hydraulic head diagram

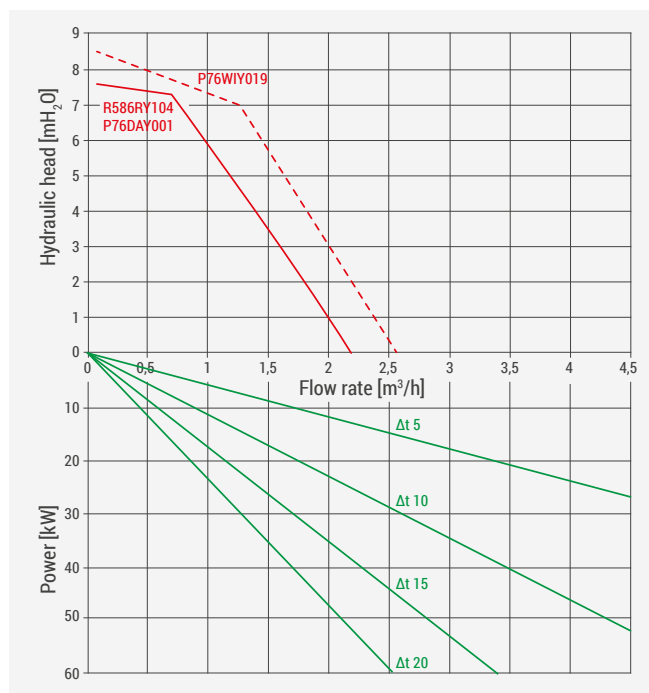

NOTE. For proper interpretation of the diagram, see example on page 17.

NOTE. Curves obtained with pump set to "constant speed, level III" mode.

NOTE. Diagram referring to the useful hydraulic head at the unit connections and mixing valve fully open.



R586RY131 / R586RY141

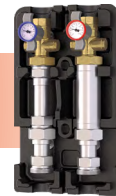

➤ Operation

R586RY131 and R586RY141 distribution units without mixing valve are used in heating and cooling systems such as relaunching units for direct outputs of high/low temperature combined systems.

The units include shut-off valves with thermometer both on the supply and return circuit and a check valve on the return spacer.

The two supply and return outputs are reversible and a R284Y021 differential by-pass kit can be installed in between (see paragraph "Main characteristics").

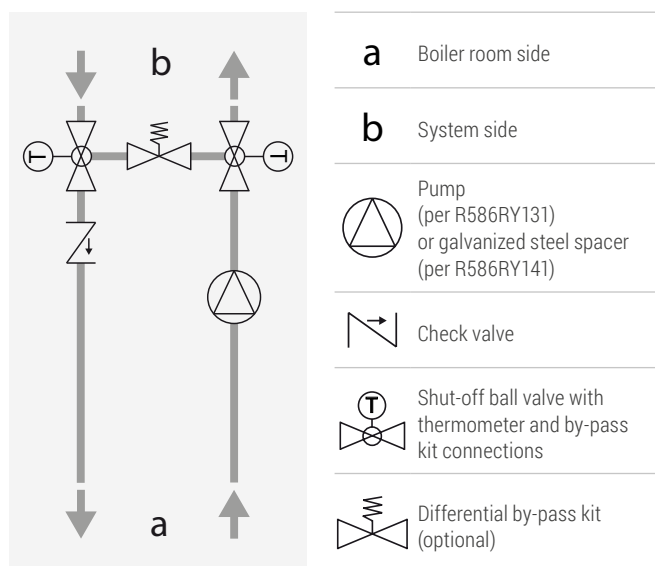

➤ Specific technical data

- Temperature range: 5÷100 °C
- Max. working pressure: 10 bar
- Connections: boiler room side: G 2" M
system side: G 1-1/4" F
outputs center distance: 125 mm
- Weight: 7,9 kg (with pump); 6,6 kg (without pump)

Materials

- Shut-off ball valves: CW617N brass body, PTFE sealings, plastic handle
- Spacer with check valve: galvanized steel body, POM check valve
- Polypropylene foam insulation (EPP)
- Gaskets: EPDM

Flow rate/power/hydraulic head diagram

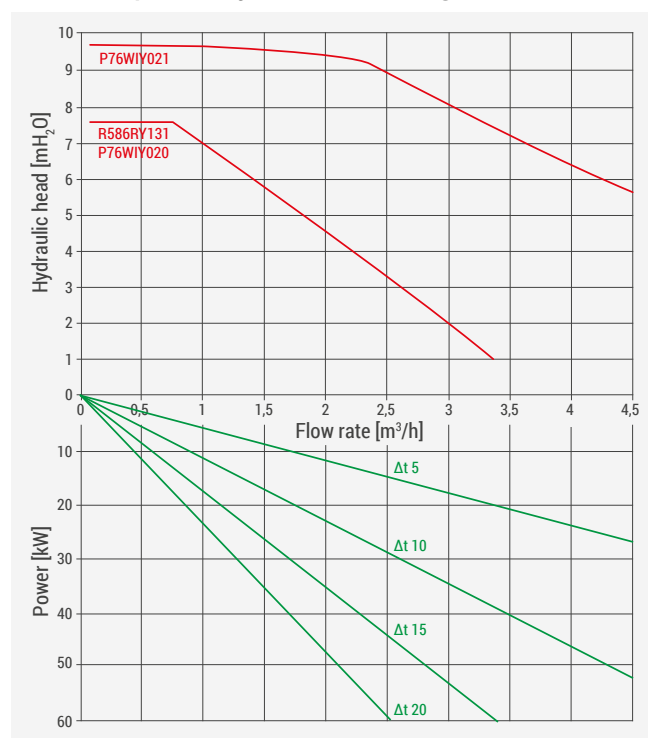

NOTE. For proper interpretation of the diagram, see example on page 17.

NOTE. Curves obtained with pump set to "constant speed, level III" mode.

NOTE. Diagram referring to the useful hydraulic head at the unit connections.



R586RY133 / R586RY143

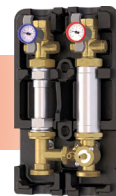

Operation

R586RY133 and R586RY143 distribution units with mixing sector valve can be used in heating and cooling systems to control the system supply temperature.

Operation is possible only when combined to an actuator and possibly a KLIMAbus thermoregulation system.

The units include an shut-off valve with thermometer on both supply and return circuits and a check valve on the return spacer.

The mixing valve is also equipped with a manually adjustable by-pass to insert the function of fixed recirculation of the system.

The two supply and return outputs are NOT reversible (see "Main Characteristics" paragraph) and a R284Y021 differential by-pass kit can be installed in between (see paragraph "Main characteristics").

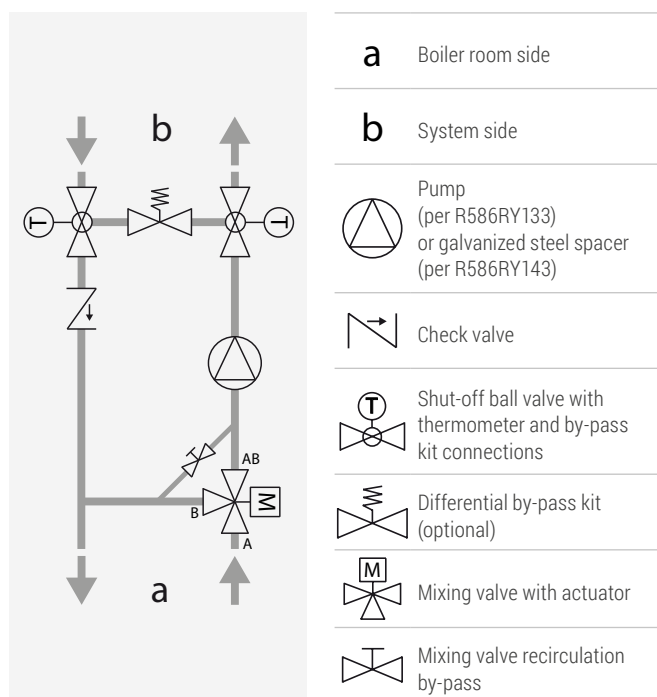

Specific technical data

- Temperature range: 5÷100 °C
- Max. working pressure: 10 bar
- Connections: boiler room side: G 2" M
system side: G 1-1/4" F
outputs center distance: 125 mm
- Weight: 8,2 kg (with pump); 6,9 kg (without pump)

Materials

- Shut-off ball valves: CW617N brass body, PTFE sealings, plastic handle
- Valvola miscelatrice: corpo in ottone, tubo di raccordo in ottone, Gaskets in EPDM, FPM e PTFE.
- Spacer with check valve: galvanneated steel body, POM check valve
- Polypropylene foam insulation (EPP)
- Gaskets: EPDM

Flow rate/power/hydraulic head diagram

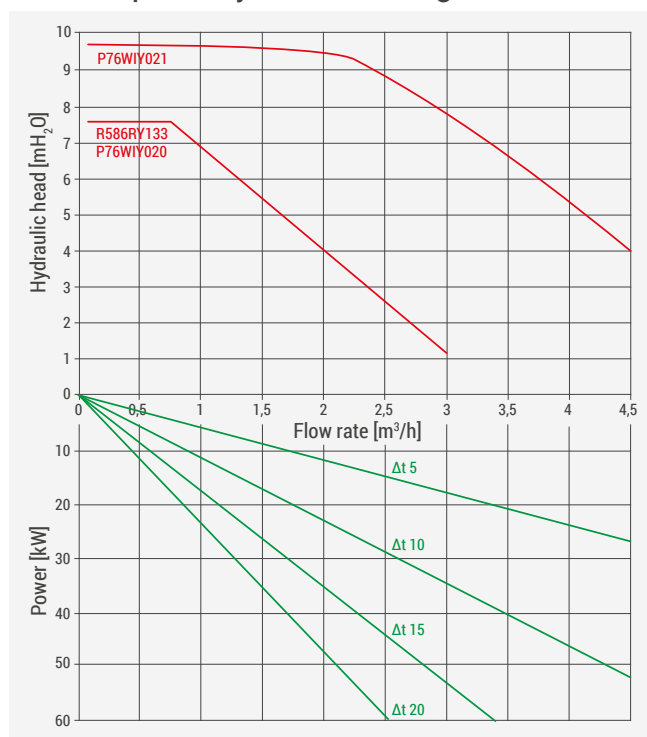

NOTE. For proper interpretation of the diagram, see example on page 17.

NOTE. Curves obtained with pump set to "constant speed, level III" mode.

NOTE. Diagram referring to the useful hydraulic head at the unit connections and mixing valve fully open.

Sector mixing valve

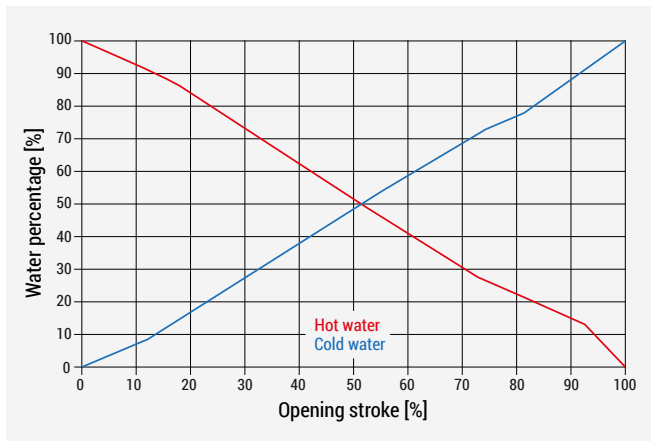

Valve with linear proportional characteristic: hot and cold water mix in an almost linear manner.

• Kv: 18

Operation of mixing valve recirculation by-pass

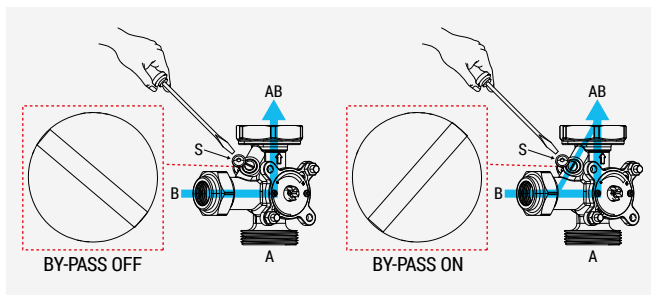

Sector mixing valve include a by-pass which activates a fix recirculation on the mixing valve (B→AB).

⚠ WARNING. Do not loosen the safety device (S) next to the by-pass adjustment screw. High pressures may violently eject it from its seat.

➤ Dimensions

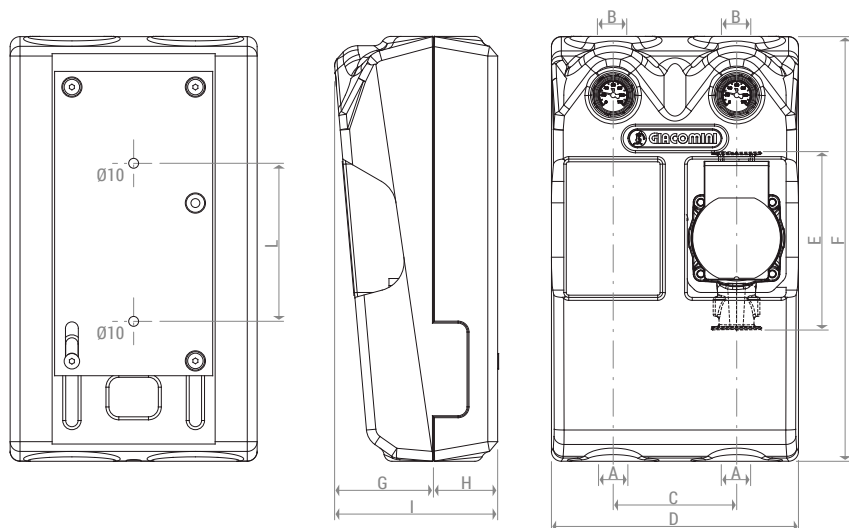

PRODUCT CODE	A x B	C [mm]	D [mm]	E [mm]	F [mm]	G [mm]	H [mm]	I [mm]	L [mm]
R586RY101									
R586RY102									
R586RY103									
R586RY104	G 1-1/2" M	125	250	180	430	100	65	165	160
R586RY111	x G 1" F								
R586RY112									
R586RY113									
R586RY114									
R586RY131									
R586RY133	G 2" M	125	280	180	475	103	65	168	160
R586RY141	x G 1-1/4" F								
R586RY143									

➤ Example of application diagram

Application diagram for heating-only system with R586SEP complete of R586RY101 for high-temperature radiator zone + R586RY102/103 for low-temperature radiant system zone and mixing valve actuator controlled by KLIMAbus thermoregulation.

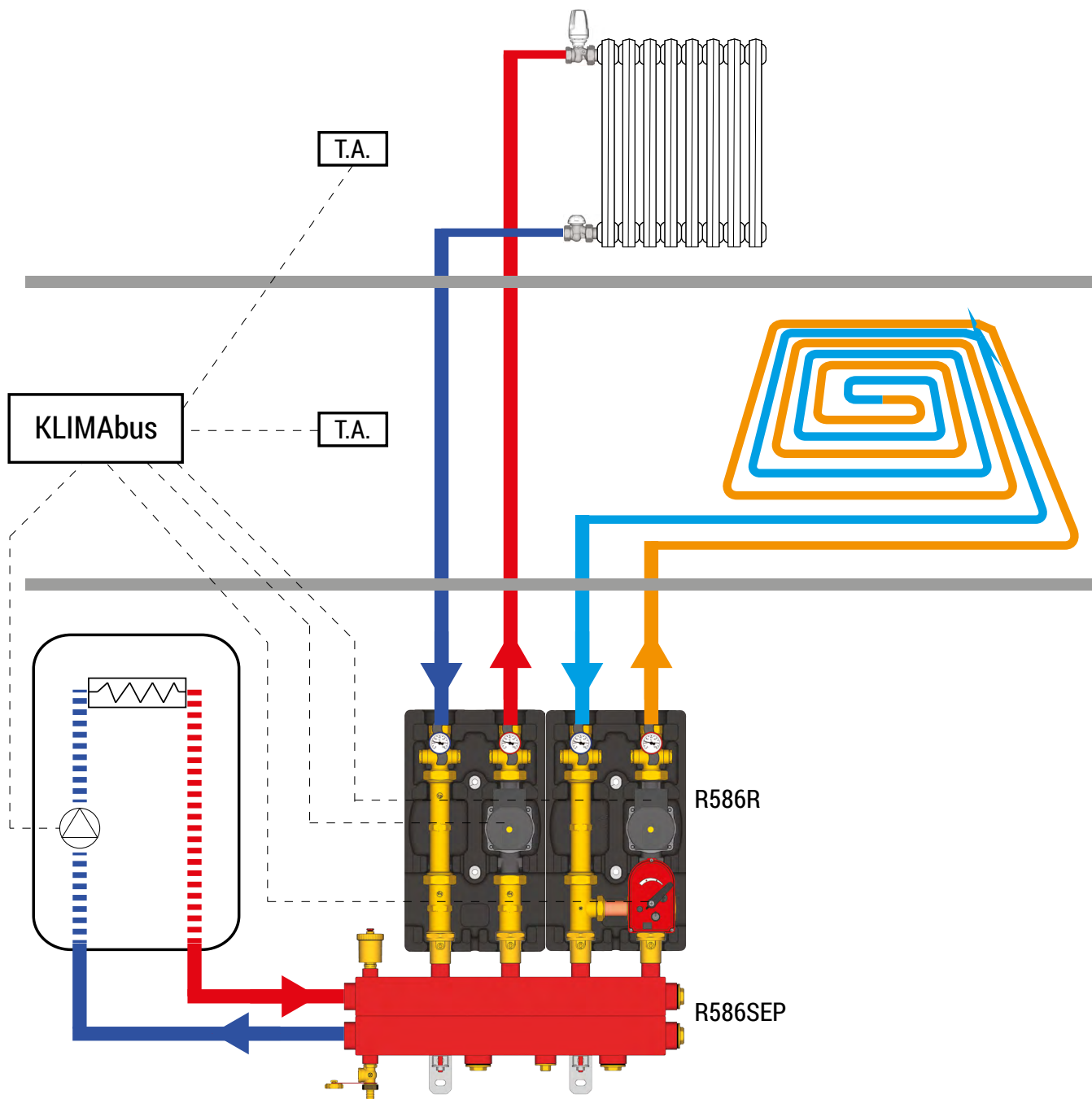

➤ Interpretation of flow rate/power/hydraulic head diagram

With the system Power and Δt project data known, trace a horizontal line starting from the Power axis up to intersecting the required Δt (A).

From the obtained intersection point, trace a vertical line up to intercepting the operational curve of the R586R unit (B), this will show the operational flow rate and hydraulic head available downstream the R586R unit (B, C).

Example:

Power = 20 kW

$\Delta t = 10\text{ }^{\circ}\text{C}$

The indications given above will result in a flow rate equal to 1,75 m³/h with a useful hydraulic head at the pump of 4,8 m.w.c.

NOTE. Curves obtained with pump set to "constant speed, level III" mode.

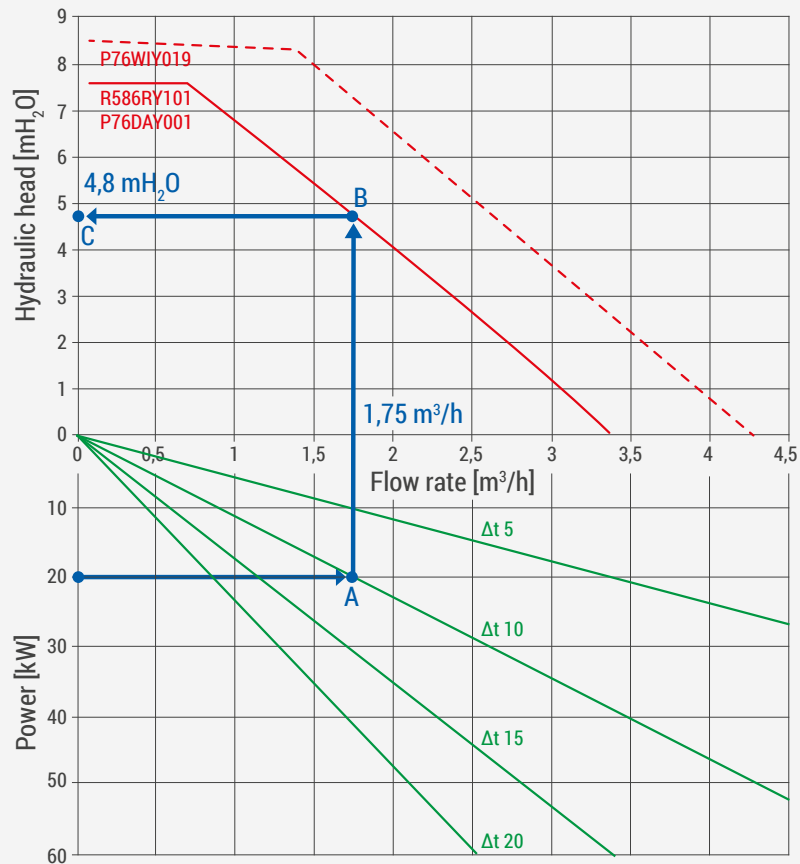

Power	Power required by the heating/cooling system zone downstream of the R586R distribution unit
Δt	Temperature difference between supply and return of the heating/cooling system zone downstream of the R586R distribution unit (Δt depends on the type of system)
Flow rate	Operational flow rate downstream of the R586R distribution unit
Hydraulic head	Hydraulic head available downstream of the R586R distribution unit
R586R unit curve	Operational curve of the R586R distribution unit (DAB EVOSTA2 70/180 pump + all various components)

➤ Standards reference

- PED 2014/68/EU, par. 4.3
- LVD 2014/35/EU
- EMC 2014/30/EU
- ErP 2009/125/EU
- RoHS 2011/65/EU
- Compliance with CE and UKCA: only for versions with pump



➤ Product specifications

R586RY101

Distribution unit to control heating and cooling of one system zone. Connections: system side G 1" F; boiler room side G 1-1/2" M; supply and return outputs center distance 125 mm. Includes: brass supply output equipped with low-energy consumption pump complying with directive ErP 2009/125/CE (center distance 180 mm) and shut-off ball valve with integrated thermometer (0÷120 °C scale); brass return output equipped with shut-off ball valve with integrated thermometer (0÷120 °C scale) and POM check valve. Reversible supply and return outputs. EPP rigid insulation (density 35 kg/m³). Wall-mount plate (screw anchors not included). EPDM gaskets. Temperature range 5÷100 °C. Max. working pressure 10 bar. Weight 5,8 kg. Optional installation of differential by-pass kit between the two supply and return outputs. Optional installation of shut-off ball valve upstream of distribution unit. Compliance with CE and UKCA.

R586RY111

Distribution unit to control heating and cooling of one system zone. Connections: system side G 1" F; boiler room side G 1-1/2" M; supply and return outputs center distance 125 mm. Includes: brass supply output equipped with spacer to install pump (center distance 180 mm) and shut-off ball valve with integrated thermometer (0÷120 °C scale); brass return output equipped with shut-off ball valve with integrated thermometer (0÷120 °C scale) and POM check valve. Reversible supply and return outputs. EPP rigid insulation (density 35 kg/m³). Wall-mount plate (screw anchors not included). EPDM gaskets. Temperature range 5÷100 °C. max. working pressure 10 bar. Weight 4,0 kg. Optional installation of differential by-pass kit between the two supply and return outputs. Optional installation of shut-off ball valve upstream of distribution unit.

R586RY102

Distribution unit to control heating and cooling of one system zone. Connections: system side G 1" F; boiler room side G 1-1/2" M; supply and return outputs center distance 125 mm. Includes: brass supply output equipped with low-energy consumption pump complying with directive ErP 2009/125/CE (center distance 180 mm, connections G 1-1/2" M), shut-off ball valve with integrated thermometer (0÷120 °C scale) and motorizable mixing ball valve; brass return output equipped with shut-off ball valve with integrated thermometer (0÷120 °C scale) and POM check valve. Reversible supply and return outputs. EPP rigid insulation (density 35 kg/m³). Wall-mount plate (screw anchors not included). EPDM gaskets. Temperature range 5÷100 °C. Max. working pressure 10 bar. Weight 6,8 kg. Optional installation of differential by-pass kit between the two supply and return outputs. Optional installation of shut-off ball valve upstream of distribution unit. Optional installation of the mixing valve actuator controllable by KLIMAbus thermoregulation items. Compliance with CE and UKCA.

R586RY112

Distribution unit to control heating and cooling of one system zone. Connections: system side G 1" F; boiler room side G 1-1/2" M; supply and return outputs center distance 125 mm. Includes: brass supply output equipped with spacer to install pump (center distance 180 mm, connections G 1-1/2" M), shut-off ball valve with integrated thermometer (0÷120 °C scale) and motorizable mixing ball valve; brass return output equipped with shut-off ball valve with integrated thermometer (0÷120 °C scale) and POM check valve. Reversible supply and return outputs. EPP rigid insulation (density 35 kg/m³). Wall-mount plate (screw anchors not included). EPDM gaskets. Temperature range 5÷100 °C. Max. working pressure 10 bar. Weight 5,0 kg. Optional installation of differential by-pass kit between the two supply and return outputs. Optional installation of shut-off ball valve upstream of distribution unit. Optional installation of the mixing valve actuator controllable by KLIMAbus thermoregulation items.

R586RY103

Distribution unit to control heating and cooling of one system zone. Connections: system side G 1" F; boiler room side G 1-1/2" M; supply and return outputs center distance 125 mm. Includes: brass supply output equipped with low-energy consumption pump complying with directive ErP 2009/125/CE (center distance 180 mm), shut-off ball valve with integrated thermometer (0÷120 °C scale) and motorizable sector mixing valve equipped with optional fix by-pass; brass return output equipped with shut-off ball valve with integrated thermometer (0÷120 °C scale) and POM check valve. Reversible supply and return outputs. EPP rigid insulation (density 35 kg/m³). Wall-mount plate (screw anchors not included). EPDM gaskets. Temperature range 5÷100 °C. Max. working pressure 10 bar. Weight 6,7 kg. Optional installation of differential by-pass kit between the two supply and return outputs. Optional installation of shut-off ball valve upstream of distribution unit. Optional installation of mixing valve actuator controllable by KLIMAbus thermoregulation items. Compliance with CE and UKCA.

R586RY113

Distribution unit to control heating and cooling of one system zone. Connections: system side G 1" F; boiler room side G 1-1/2" M; supply and return outputs center distance 125 mm. Includes: brass supply output equipped with spacer to install pump (center distance 180 mm, connections G 1-1/2" M), shut-off ball valve with integrated thermometer (0÷120 °C scale) and motorizable sector mixing valve equipped with optional fix by-pass; brass return output equipped with shut-off ball valve with integrated thermometer (0÷120 °C scale) and POM check valve. Reversible supply and return outputs. EPP rigid insulation (density 35 kg/m³). Wall-mount plate (screw anchors not included). EPDM gaskets. Temperature range 5÷100 °C. Max. working pressure 10 bar. Weight 4,9 kg. Optional installation of differential by-pass kit between the two supply and return outputs. Optional installation of shut-off ball valve upstream of distribution unit. Optional installation of mixing valve actuator controllable by KLIMAbus thermoregulation items.

R586RY104



Giacomini S.p.A.

Via per Alzo 39, 28017 San Maurizio d'Opaglio (NO) Italia

consulenza.prodotti@giacomini.com

+39 0322 923372 - giacomini.com

Distribution unit to control heating and cooling of one system zone. Connections: system side G 1" F; boiler room side G 1-1/2" M; supply and return outputs center distance 125 mm. Includes: brass supply output equipped with low-energy consumption pump complying with directive ErP 2009/125/CE (center distance 180 mm), shut-off ball valve with integrated thermometer (0÷120 °C scale) and thermostatic mixing valve; brass return output equipped with shut-off ball valve with integrated thermometer (0÷120 °C scale) and POM check valve. Reversible supply and return outputs. EPP rigid insulation (density 35 kg/m³). Wall-mount plate (screw anchors not included). EPDM gaskets. Temperature range 5÷95 °C. Max. working pressure 5 bar. Weight 7,0 kg. Optional installation of differential by-pass kit between the two supply and return outputs. Optional installation of shut-off ball valve upstream of distribution unit. Compliance with CE and UKCA.

R586RY114

Distribution unit to control heating and cooling of one system zone. Connections: system side G 1" F; boiler room side G 1-1/2" M; supply and return outputs center distance 125 mm. Includes: brass supply output equipped with spacer for to install pump (center distance 180 mm, connections G 1-1/2" M), shut-off ball valve with integrated thermometer (0÷120 °C scale) and thermostatic mixing valve; brass return output equipped with shut-off ball valve with integrated thermometer (0÷120 °C scale) and POM check valve. Reversible supply and return outputs. EPP rigid insulation (density 35 kg/m³). Wall-mount plate (screw anchors not included). EPDM gaskets. Temperature range 5÷95 °C. Max. working pressure 5 bar. Weight 5,2 kg. Optional installation of differential by-pass kit between the two supply and return outputs. Optional installation of shut-off ball valve upstream of distribution unit.

R586RY131

Distribution unit to control heating and cooling of one system zone. Connections: system side G 1-1/4" F; boiler room side G 2" M; supply and return outputs center distance 125 mm. Includes: brass supply output equipped with low-energy consumption pump complying with directive ErP 2009/125/CE (center distance 180 mm) and shut-off ball valve with integrated thermometer (0÷120 °C scale); brass return output equipped with shut-off ball valve with integrated thermometer (0÷120 °C scale) and POM check valve. Reversible supply and return outputs. EPP rigid insulation (density 35 kg/m³). Wall-mount plate (screw anchors not included). EPDM gaskets. Temperature range 5÷100 °C. Max. working pressure 10 bar. Weight 7,9 kg. Optional installation of differential by-pass kit between the two supply and return outputs. Optional installation of shut-off ball valve upstream of distribution unit. Compliance with CE and UKCA.

R586RY141

Distribution unit to control heating and cooling of one system zone. Connections: system side G 1-1/4" F; boiler room side G 2" M; supply and return outputs center distance 125 mm. Includes: brass supply output equipped with spacer to install pump (center distance 180 mm) and shut-off ball valve with integrated thermometer (0÷120 °C scale); brass return output equipped with shut-off ball valve with integrated thermometer (0÷120 °C scale) and POM check valve. Reversible supply and return outputs. EPP rigid insulation (density 35 kg/m³). Wall-mount plate (screw anchors not included). EPDM gaskets. Temperature range 5÷100 °C. Max. working pressure 10 bar. Weight 6,6 kg. Optional installation of differential by-pass kit between the two supply and return outputs. Optional installation of shut-off ball valve upstream of distribution unit.

R586RY133

Distribution unit to control heating and cooling of one system zone. Connections: system side G 1-1/4" F; boiler room side G 2" M; supply and return outputs center distance 125 mm. Includes: brass supply output equipped with low-energy consumption pump complying with directive ErP 2009/125/CE (center distance 180 mm), shut-off ball valve with integrated thermometer (0÷120 °C scale) and motorizable sector mixing valve equipped with optional fix by-pass; brass return output equipped with shut-off ball valve with integrated thermometer (0÷120 °C scale) and POM check valve. Reversible supply and return outputs. EPP rigid insulation (density 35 kg/m³). Wall-mount plate (screw anchors not included). EPDM gaskets. Temperature range 5÷100 °C. Max. working pressure 10 bar. Weight 8,2 kg. Optional installation of differential by-pass kit between the two supply and return outputs. Optional installation of shut-off ball valve upstream of distribution unit. Optional installation of mixing valve actuator controllable by KLIMAbus thermoregulation items. Compliance with CE and UKCA.

R586RY143

Distribution unit to control heating and cooling of one system zone. Connections: system side G 1-1/4" F; boiler room side G 2" M; supply and return outputs center distance 125 mm. Includes: brass supply output equipped with spacer to install pump (center distance 180 mm, connections G 1-1/2" M), shut-off ball valve with integrated thermometer (0÷120 °C scale) and motorizable sector mixing valve equipped with optional fix by-pass; brass return output equipped with shut-off ball valve with integrated thermometer (0÷120 °C scale) and POM check valve. Reversible supply and return outputs. EPP rigid insulation (density 35 kg/m³). Wall-mount plate (screw anchors not included). EPDM gaskets. Temperature range 5÷100 °C. Max. working pressure 10 bar. Optional installation of differential by-pass kit between the two supply and return outputs. Weight 6,9 kg. Optional installation of shut-off ball valve upstream of distribution unit. Optional installation of mixing valve actuator controllable by KLIMAbus thermoregulation items.

⚠ Safety Warning. Installation, commissioning and periodical maintenance of the product must be carried out by qualified operators in compliance with national regulations and/or local standards. A qualified installer must take all required measures, including use of Individual Protection Devices, for his and others' safety. An improper installation may damage people, animals or objects towards which Giacomini S.p.A. may not be held liable.

♻ Package Disposal. Carton boxes: paper recycling. Plastic bags and bubble wrap: plastic recycling.

ℹ Additional information. For more information, go to giacomini.com or contact our technical assistance service. This document provides only general indications. Giacomini S.p.A. may change at any time, without notice and for technical or commercial reasons, the items included herewith. The information included in this technical sheet do not exempt the user from strictly complying with the rules and good practice standards in force.

♻ Product Disposal. Do not dispose of product as municipal waste at the end of its life cycle. Dispose of product at a special recycling platform managed by local authorities or at retailers providing this type of service.